

- Design note**
- All Dimension are in Millimetre, Expected otherwise shown.
 - Antenna Configuration:
 - 3 Nos GSM Antenna below 750 Mtr below top level
 - 3 Nos GSM Antenna below 3250 Mtr below top level
 - 3 Nos RRU below 9150 Mtr from below top level
 - Material:
 - All Structure steel should be hot-dip galvanized confirming to IS standards Grade of bolt should be as per code IS:4000-1992
 - Anchor bolts should be as per 5.6 grade
 - Fall Arrest safety system should be included along with all monopoles

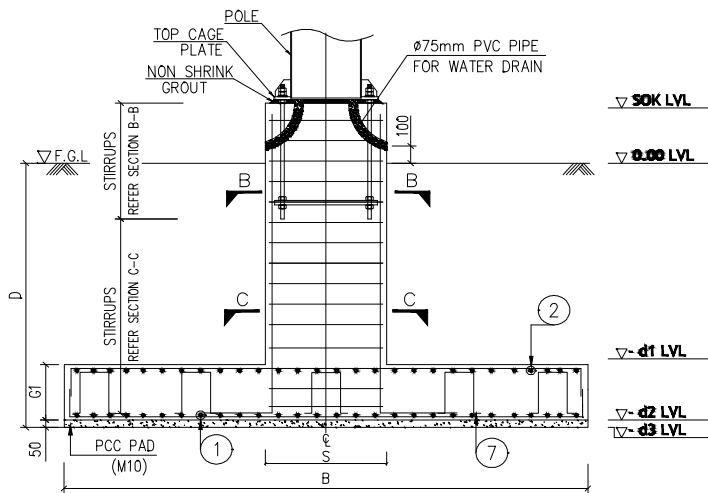

FOUNDATION DETAIL
(SECTION "A-A")

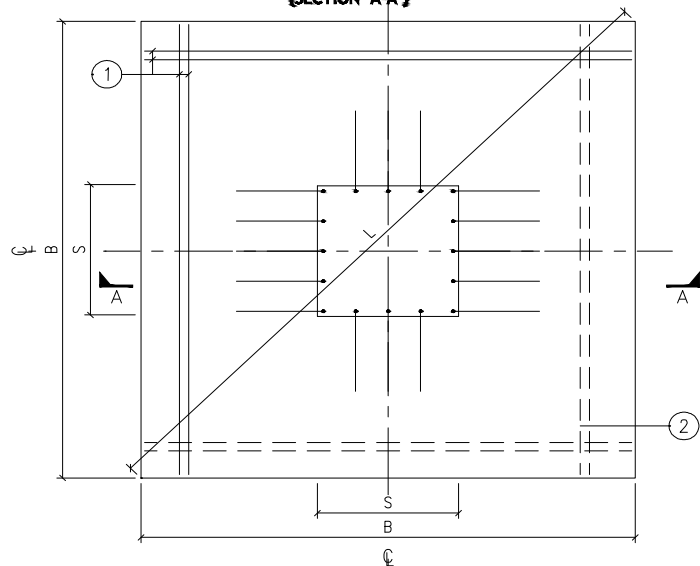

FOUNDATION PLAN
(SHOWING BOTTOM & TOP REINFORCEMENT DETAILS)

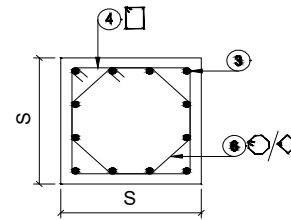

SECTION "B-B"

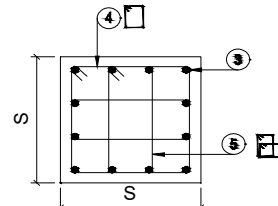

SECTION "C-C"

Dimensions	
L	3.748 m
B	2.650 m
S	0.850 m
D	1.750 m
d1	1.450 m
d2	1.450 m
d3	1.700 m
SOK lvl	0.500 m
Section B-B	600 mm
Section C-C	1530 mm

BAR BENDING SCHEDULE							
#	Shape of Bar	Length of Bar (mm)	Dia. of Bar (mm)	Spacing (mm)	No. of Bars	Unit Weight	Total Weight per Pole
1		2800	12	130	42	0.89	104.7
2		2800	12	250	24	0.89	59.8
3		2800	20	-	12	2.47	83.0
4		3200	8	150	15	0.39	18.7
5		2250	8		44	0.39	38.6
6		2600	8	150	5	0.39	5.1
7		800	12	750	16	0.89	11.4
Weight of steel (kg)							321.3
Wastage and splices (kg)							16.1
Total Steel Quantity (kg)							337.3

Foundation Quantity		
Items	Pole	Units
Concrete	3.16	cum
PCC	0.4	cum
Steel	337.3	kg
Shuttering	9.3	sq.m
Excavation	23.4	cum