

NOTES:

- a. Batteries are located inside the trays of MS HRCA sheet painted with RAL9003(Signal white) colour.Trays are mounted on C-Channels.
- b. All cell connectors are made of lead coated copper busbar.
- c. No seperate foundation is required for installation of battery bank.
- d. No special ventilation is required.Normal ventilation is sufficient.
- e. All the connectors are designed for 1241 A current.
- f. Floor area required for battery bank is 5683X570 sq mm
- g. 0.5 to 1 mts aisle space on all sides should be provided to permit initial installation service and surveillance.
- h. For any correspondence quote DRG.NO:

*** Floor Load : 2203Kg/sq.m.

***. All the connectors are designed for 3hrs discharge rate.

*** Manufacturer's Model No: IP2X111(3*IP2X37)

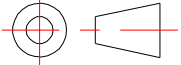
UNLESS OTHERWISE SPECIFIED TOLERANCES ON		TITLE:			 AMARA RAJA Gotta be a better way Amara Raja Energy & Mobility Limited (Formerly Known as Amara Raja Batteries Limited) Registered office&works Karakambadi-517520,TPT,(A.P) INDIA. Ph.(0877)2265000,FAX:(0877)2265600.
LINEAR	ANGULAR	48V-4590Ah SYSTEM INSTALLATION DIAGRAM			
X ±10.0 .X ± .XX ±	AS SPECIFIED IN THE DRAWING				UNLESS OTHERWISE SPECIFIED DIMENSIONS IN MILLIMETRES
		DRN.	SIGN.	DATE	SCALE: N.T.S  23 502 380 A
		CHD.	ANIL	26.02.24	
		RECHD.	ASHOK	26.02.24	
		APPD.	KMSN	26.02.24	
SHEET SIZE A3 (297 x 420T)		PROPRIETARY MATERIAL OF M/s AMARARAJA GROUP OF COMPANIES.TIRUPATI ALL RIGHTS RESERVED NO COPYING PERMITTED UNAUTHORISED USE PROHIBITED.			SHEET 1 OF: 2

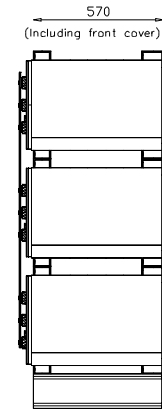
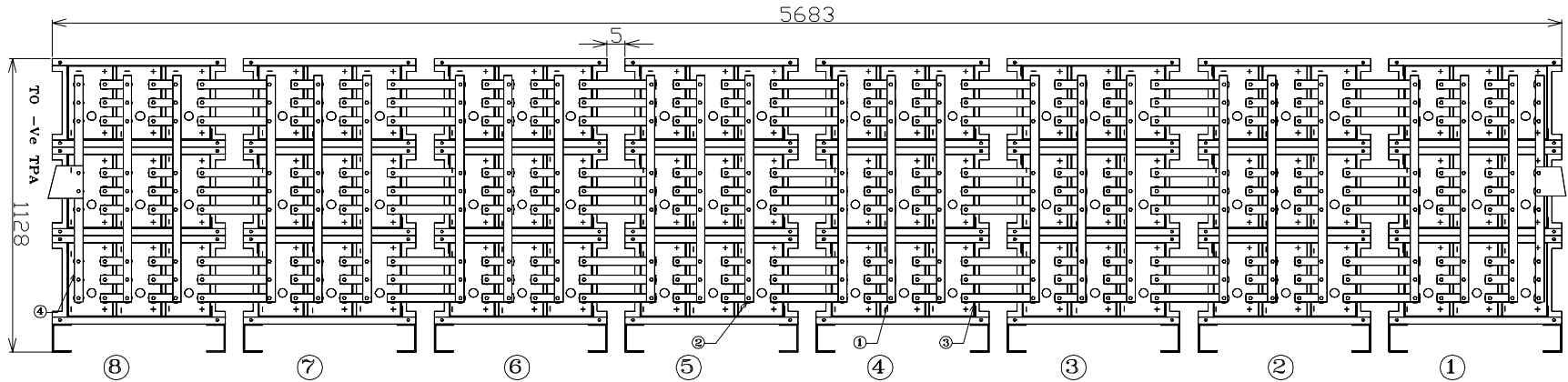

Connection diagram front view

SIDE VIEW

ITEM NO	DESCRIPTION	DIMENSIONS	QTY/CON	QTY/SYS
4	Inter module connector	880X38X12	1	02
3	Inter stack connector	210X25X2	1	63
2	Inter module connector	880X25X2	1	23
1	Inter cell connector(H)	110X25X2	1	144

CONNECTOR DETAILS

SYSTEM DETAILS	
Type of cell	2V-4590Ah
Total no. of cells	24
Volts per cell	2V
No. of modules	24
Total system weight (Approx)	7136Kgs

UNLESS OTHERWISE SPECIFIED TOLERANCES ON	
LINEAR	ANGULAR
X ±10.0	AS SPECIFIED
.X ±	IN THE
.XX ±	DRAWING

UNLESS OTHERWISE SPECIFIED DIMENSIONS IN MILLIMETRES	
WEIGHT TOLERANCE : ± 5%	
SHEET SIZE A3 (297 x 420T)	

TITLE:		
48V-4590Ah SYSTEM CONNECTION DIAGRAM		
DRN.	SIGN.	DATE
CHD.	ASHOK	26.02.24
RECHD.	ANIL	26.02.24
APPD.	KMSN	26.02.24
SCALE: N.T.S		
PROPRIETARY MATERIAL OF M/S AMARARAJA GROUP OF COMPANIES. TIRUPATI ALL RIGHTS RESERVED NO COPYING PERMITTED UNAUTHORISED USE PROHIBITED.		



AMARARAJA
Gotta be a better way

Amara Raja Energy & Mobility Limited
(Formerly Known as Amara Raja Batteries Limited)
Registered office & works
Karakambadi-517520, TPT, (A.P) INDIA.
Ph. (0877)2285000, FAX: (0877)2285600.

DRG. NO.
23 502 380 A
SHEET 2 OF: 2