

PERSPECTIVE VIEW

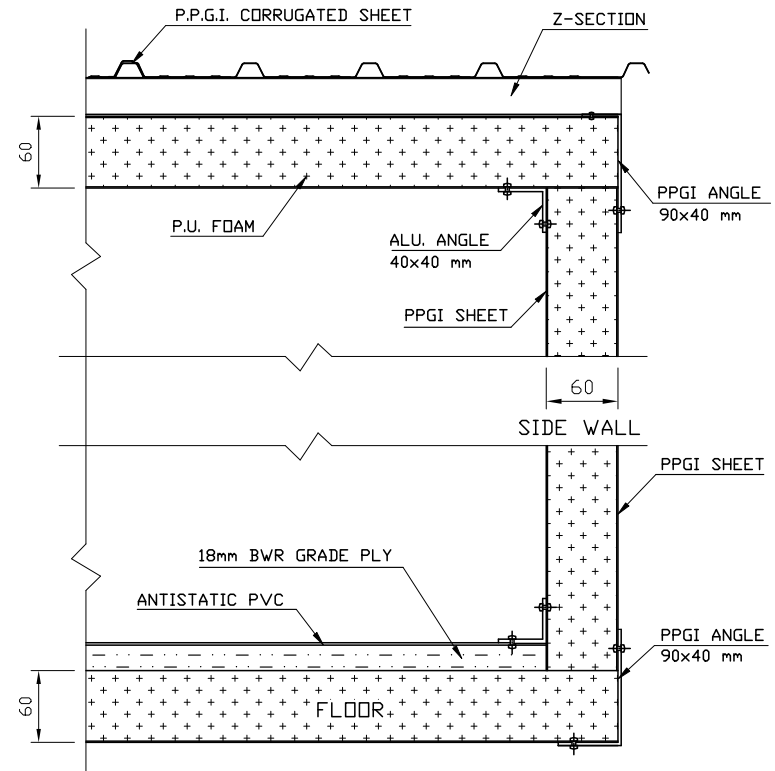

SECTION 'A-A'
SCALE 10:1

GENERAL TOLERANCE :

Reinforcement M.S. Tube : Thickness +/- 0.2 mm
Width / Depth : +/- 2.0 mm

BWR Ply : Thickness +/- 1.0 mm

ISMB : LENGTH +/- 6.0 mm

DIMENSION :

EXT : 3600x2600x2500 mm
INT : 3480x2480x2380 mm
PANEL THICKNESS : 60 mm
SKIN : 0.6mm PPGI SHEET - RAL 9002 (OUTER)
 : 0.6mm PPGI SHEET - RAL 9002 (INNER)
FLASHING : 0.8mm PPGI L-ANGLES (OUTER)
 : 2.0mm ALU. L-ANGLES (INNER)

ALL DIMENSIONS ARE IN mm

BHUTAN TELECOM LIMITED

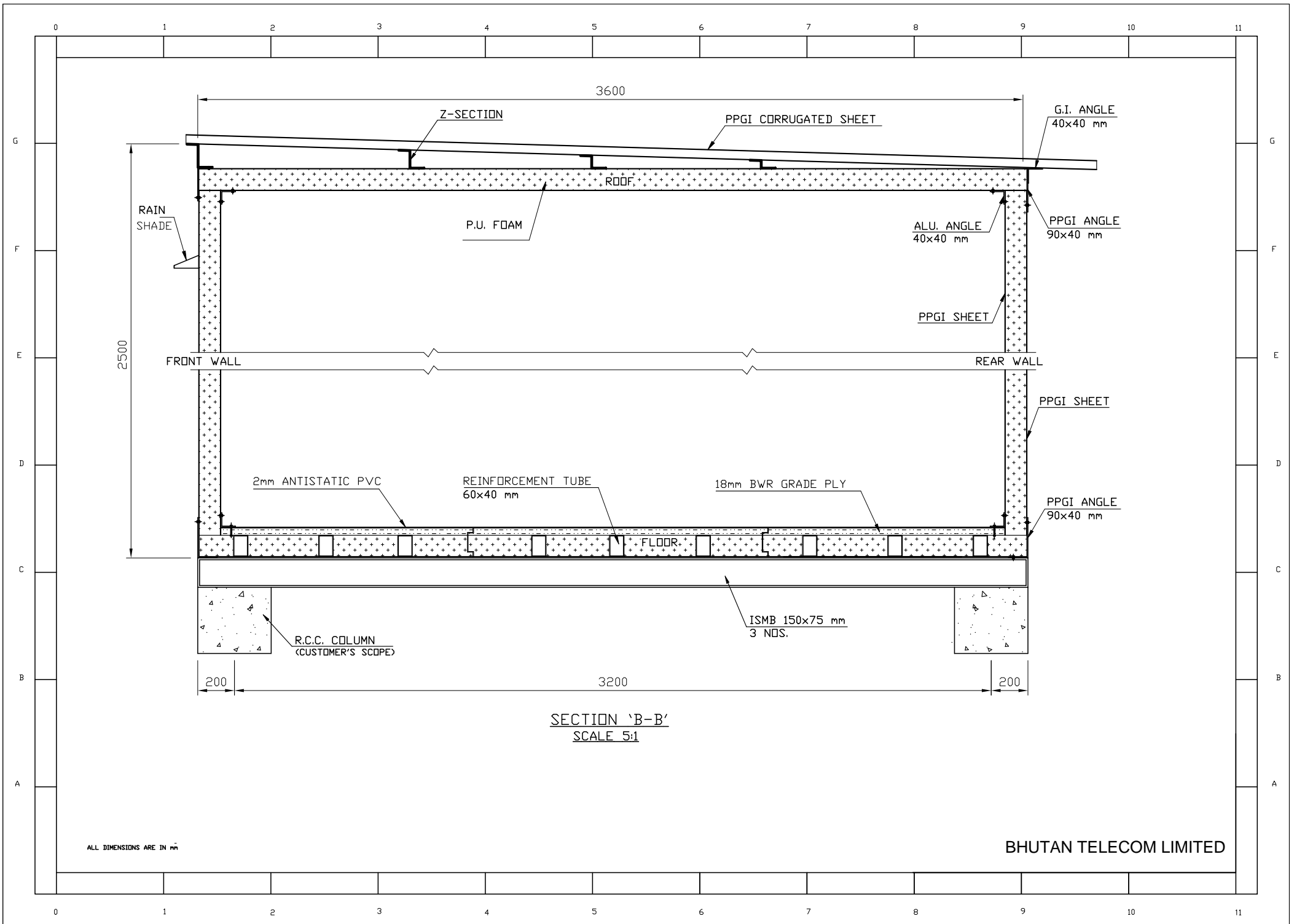

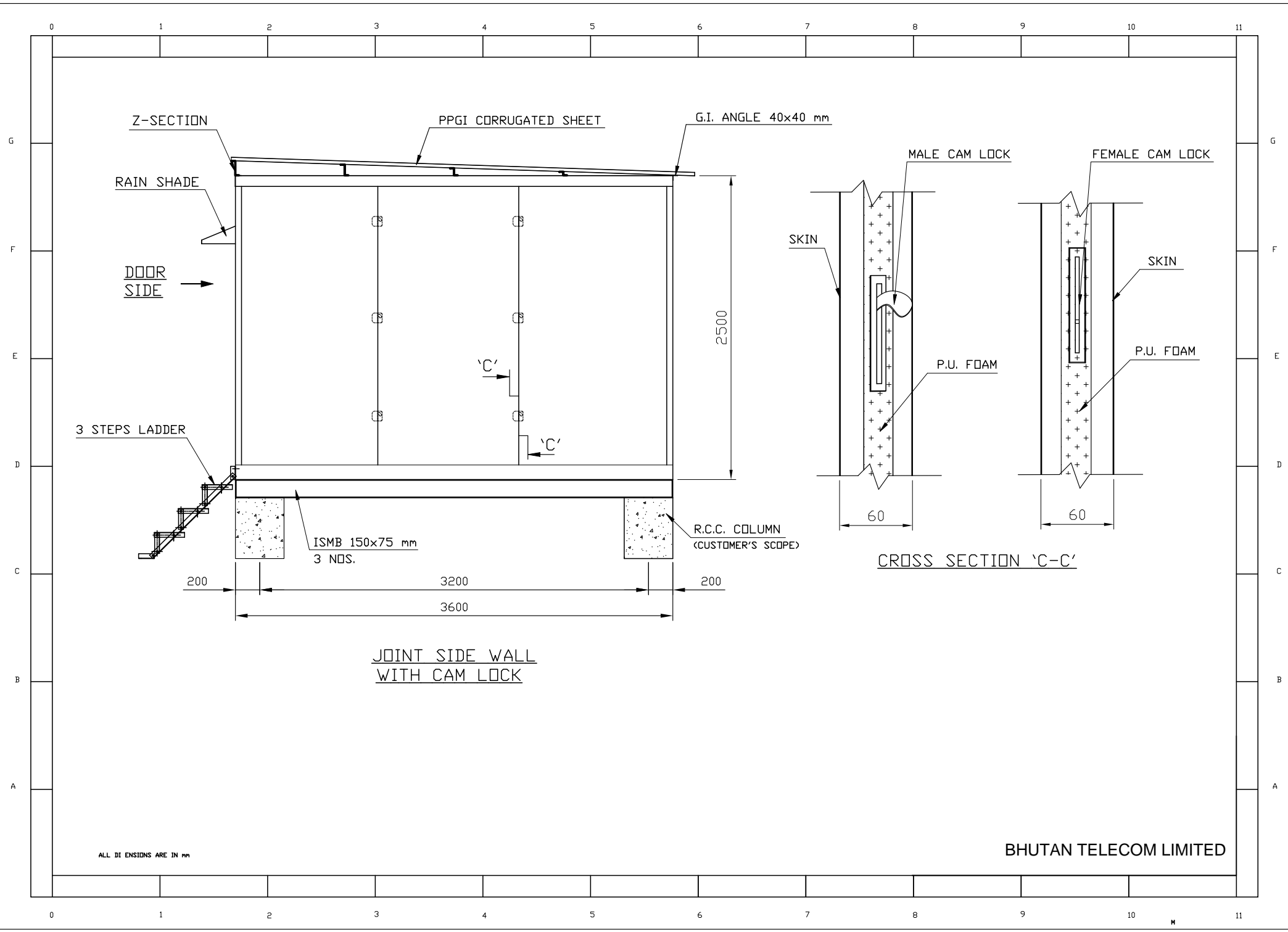

ALL DIMENSIONS ARE IN MM

BHUTAN TELECOM LIMITED

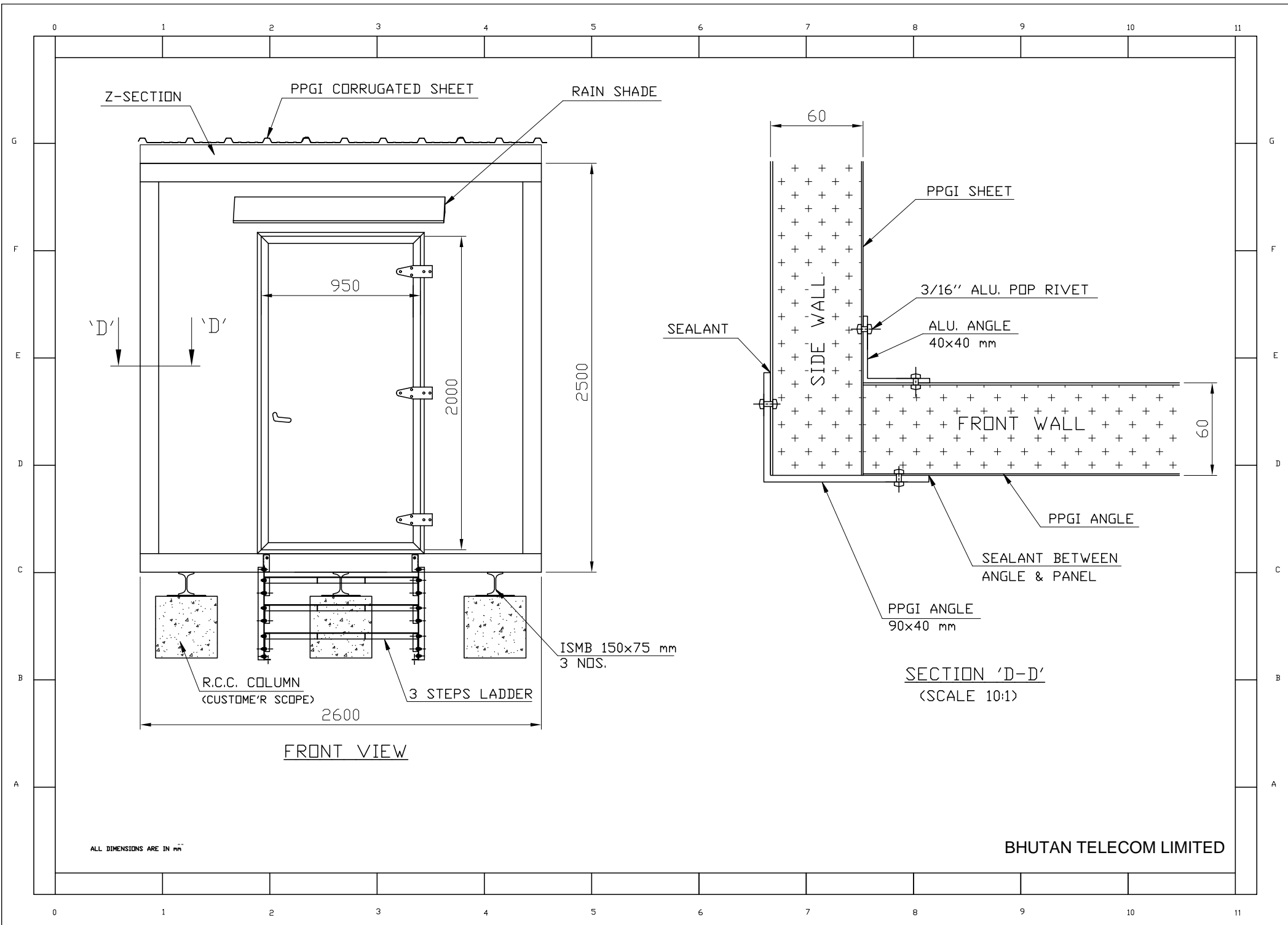

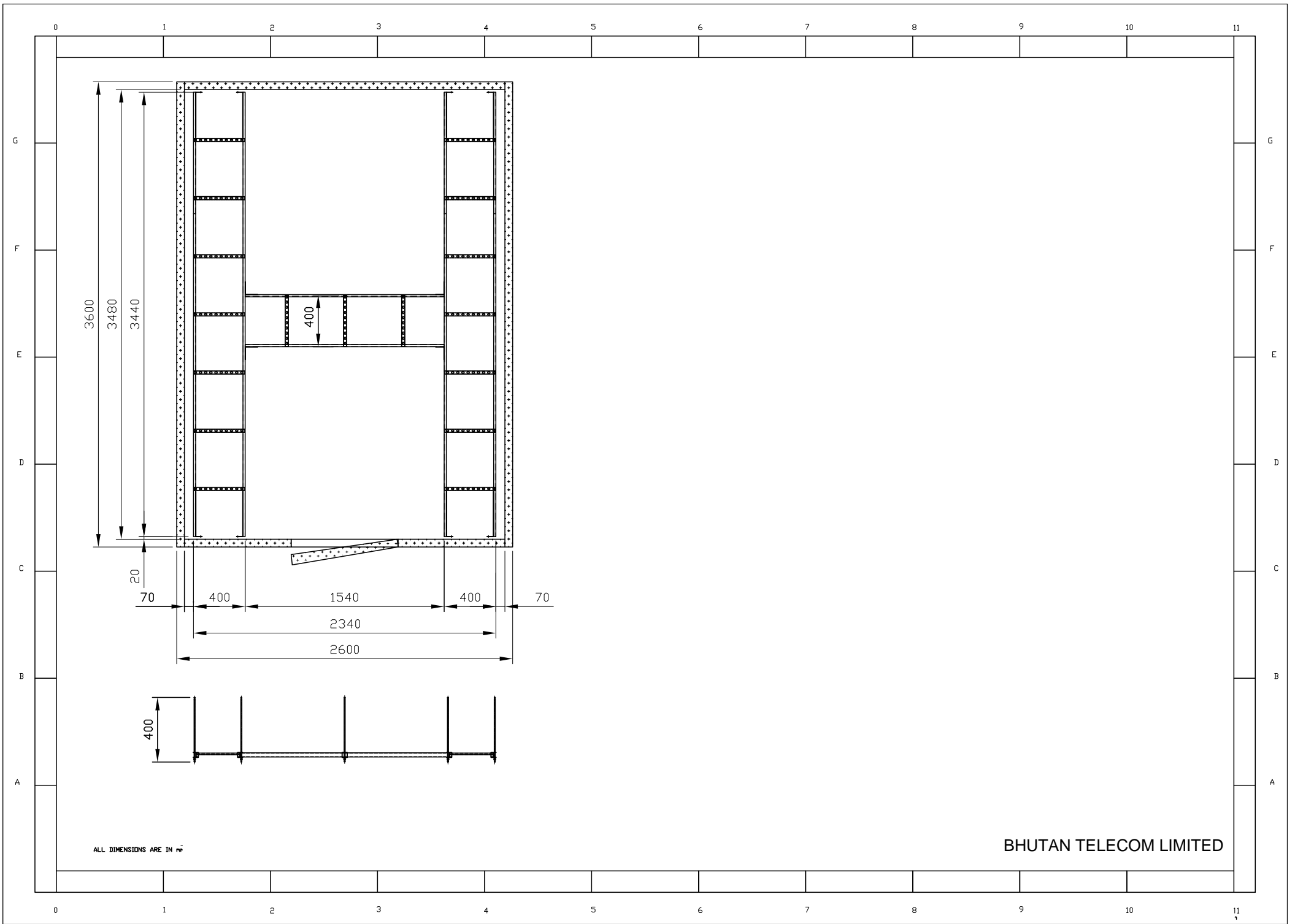

ALL DIMENSIONS ARE IN mm

BHUTAN TELECOM LIMITED

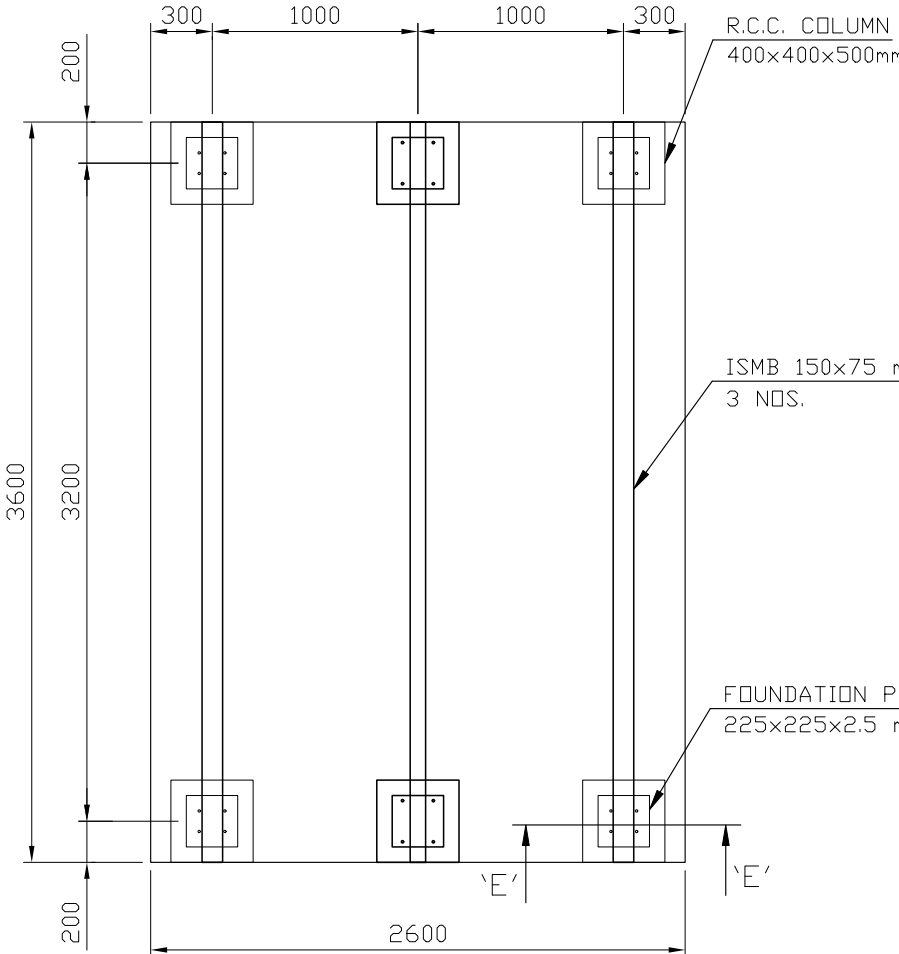
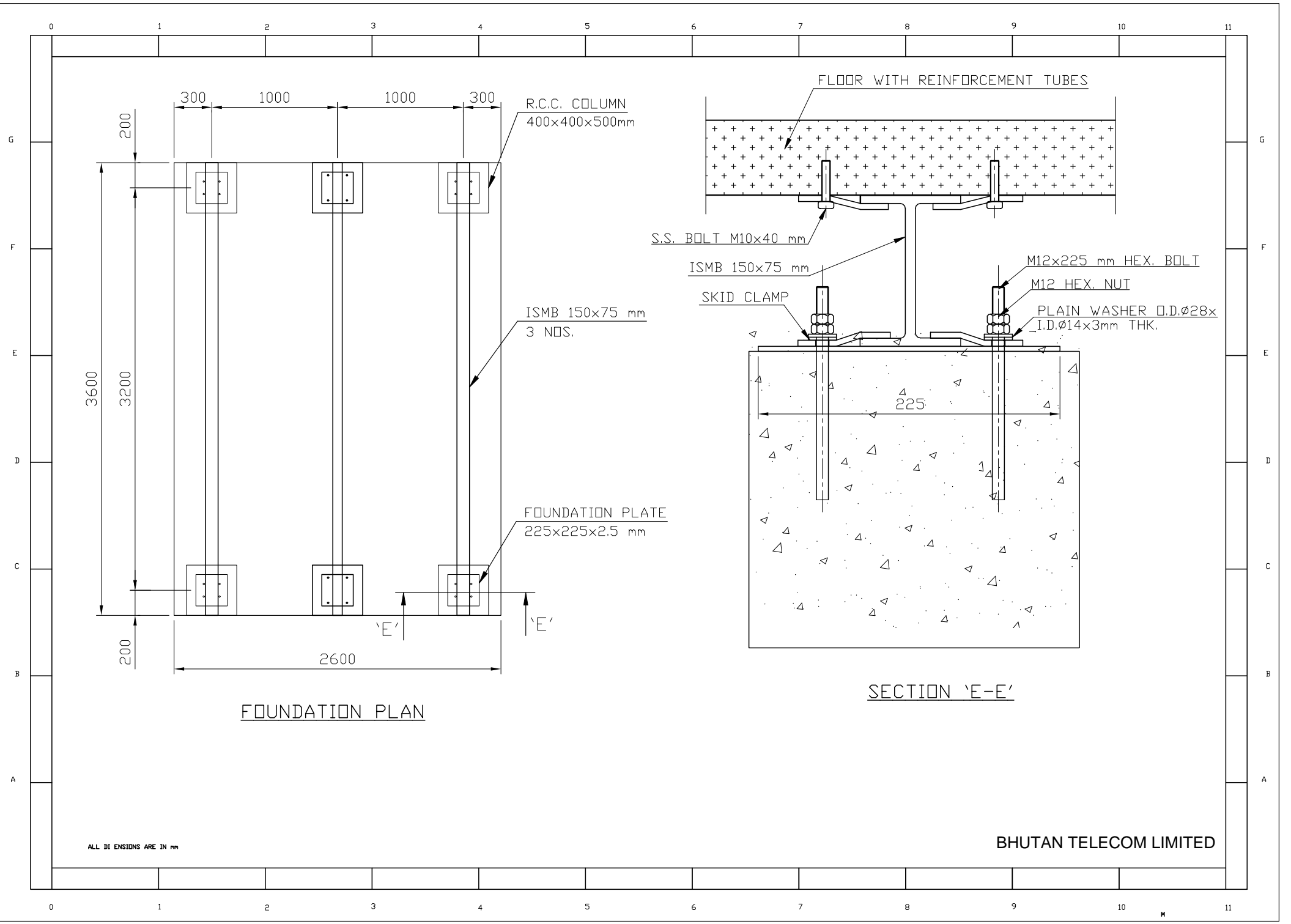

FOUNDATION PLAN

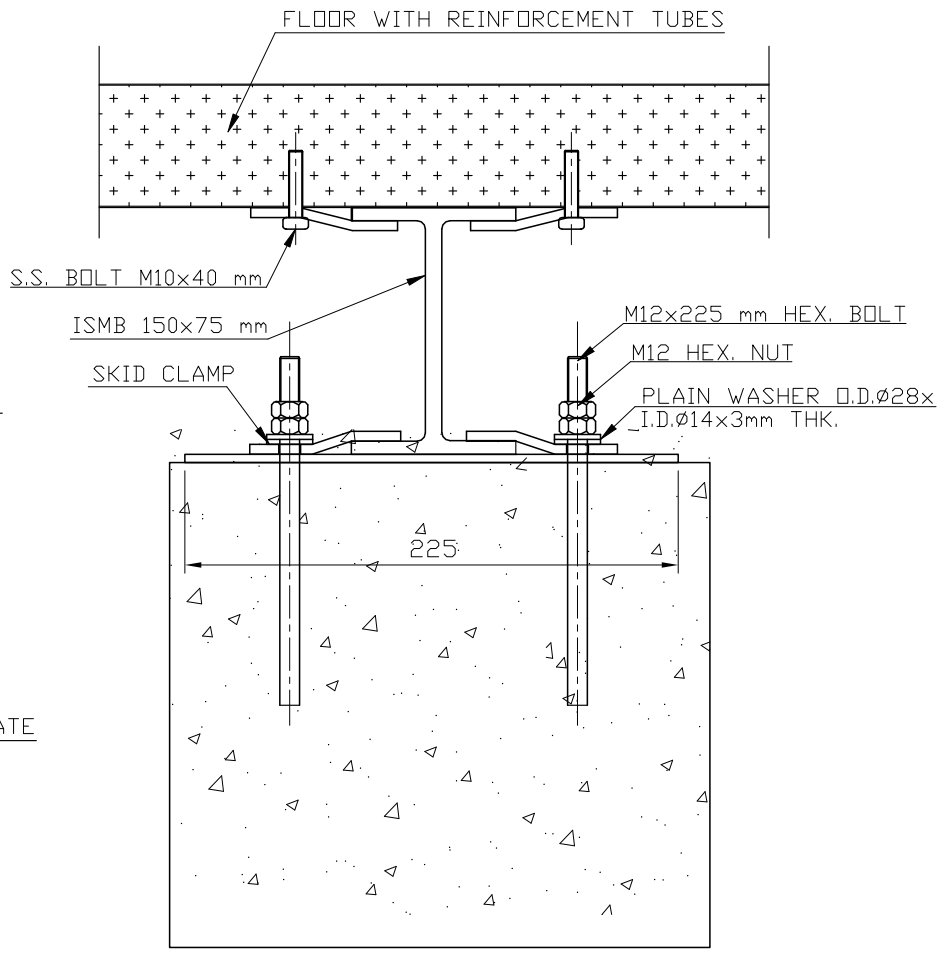

SECTION 'E-E'

ALL DIMENSIONS ARE IN mm

BHUTAN TELECOM LIMITED